

CY3B-Z Series

ø6, ø10, ø15, ø20, ø25
ø32, ø40, ø50, ø63



Replacement Parts: Seal Kit

CY3B6, 10-□Z

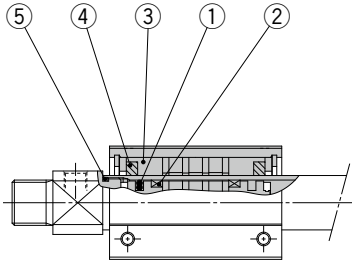

CY3B15 to 40-□Z

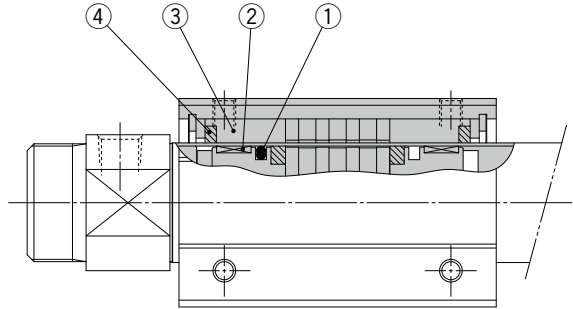

Component Parts

No.	Description
1	Piston seal
2	Wear ring A
3	Wear ring B
4	Lube-retainer B
5	Cylinder tube gasket

Seal Kit/Part Nos.

Bore size [mm]	Part no.	Contents
6	CY3B6-Z-PS	① (2 pcs.), ② (4 pcs.), ③ (2 pcs.), ⑤ (2 pcs.)
10	CY3B10-Z-PS	① (1 pc.), ③ (2 pcs.), ④ (2 pcs.), ⑤ (2 pcs.)
15	CY3B15-Z-PS	① (1 pc.), ② (4 pcs.), ③ (2 pcs.), ④ (2 pcs.)
20	CY3B20-Z-PS	① (1 pc.), ② (2 pcs.), ③ (2 pcs.), ④ (2 pcs.)
25	CY3B25-Z-PS	
32	CY3B32-Z-PS	
40	CY3B40-Z-PS	

- * As sizes ø50 and ø63 cannot be disassembled, the seal kit cannot be replaced.
- * The seal kit includes a grease pack (10 g).
Order with the following part number when only the grease pack is required.
Grease pack part number: GR-S-010
- * For replacement of the ø10 wear ring A, please contact SMC.