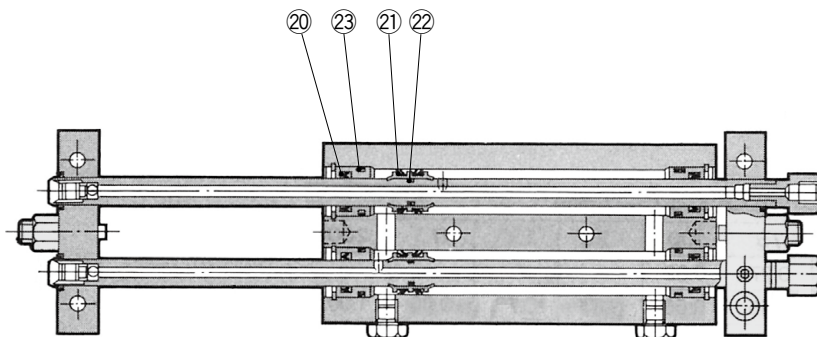
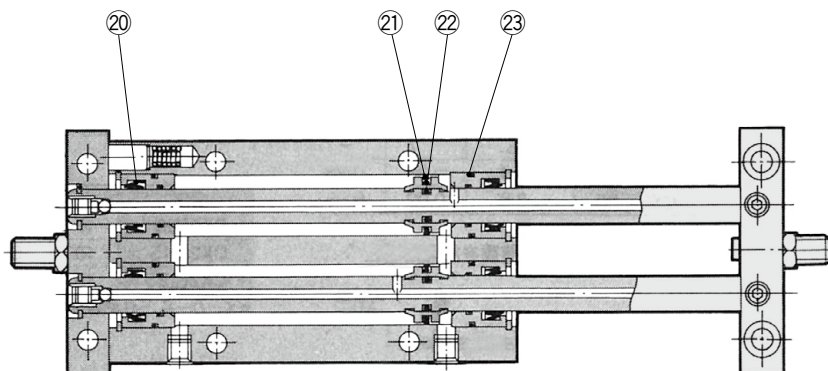

Construction**CX2N10****CX2N15, 25**

* The numbers correspond with those in the "Construction" of the CX2 series in the **Web Catalog**.

Seal Kit List

No.	Description	Material	Note
②①	Rod seal	NBR	22 is a non-replaceable part, so it is not included in the seal kit.
②②	Piston seal		
②③	Piston gasket		
②④	Cylinder tube gasket		

Replacement Parts: Seal Kit

Model	Part no.	Contents
CX2N10	CX2N10-PS	Set of nos. ②①, ②②, ②③
CX2N15	CX2N15-PS	
CX2N25	CX2N25-PS	

* The seal kit includes ②①, ②②, ②③. Order the seal kit based on each bore size. (The piston gasket ②③ is not replaceable.)

* Since the seal kit does not include a grease pack, it should be ordered separately.

Grease pack part no.: GR-S-010 (10 g)

Actuators

Rotary Actuators
Air GrippersModular F.R.L.
Pressure Control EquipmentAir Preparation
Equipment

Industrial Filters

Replacement
Procedure

Actuators

Rotary Actuators
Air GrippersModular F.R.L.
Pressure Control EquipmentAir Preparation Equipment
Industrial Filters