

Booster Relay

IL100 Series

- Used when the piping distance between instrumentation and operational area is long, or when operational area has large capacity.
- Can help accelerate actuation speed considerably.

How to Order

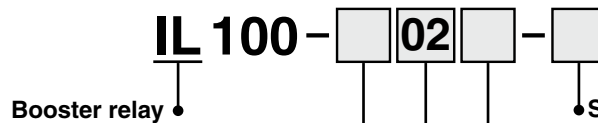

Thread type

Nil	Rc
N	NPT*
F	G*

* Semi-standard

Port size

02	1/4
03	3/8

Suffix

Nil	Standard
T	High temperature (-5 to 100°C)
L	Low temperature (-30 to 60°C)
S	Copper-free
ST	Copper-free/High temperature (-5 to 100°C)
SL	Copper-free/Low temperature (-30 to 60°C)

Accessories

Nil	None
B	With bracket



Standard Specifications

Supply pressure	Max. 1.0 MPa
Input pressure	Max. 0.7 MPa
Output pressure	Max. 0.7 MPa
Pressure ratio	1 : 1
Air consumption	3 L/min (ANR) or less (OUT = 0.5 MPa)
Linearity	Within ±1%
Hysteresis	Within 1%
Ambient and fluid temperature	-5 to 60°C
Port size	1/4, 3/8
Weight	0.56 kg

Symbol

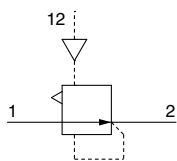

Flow Rate Characteristics

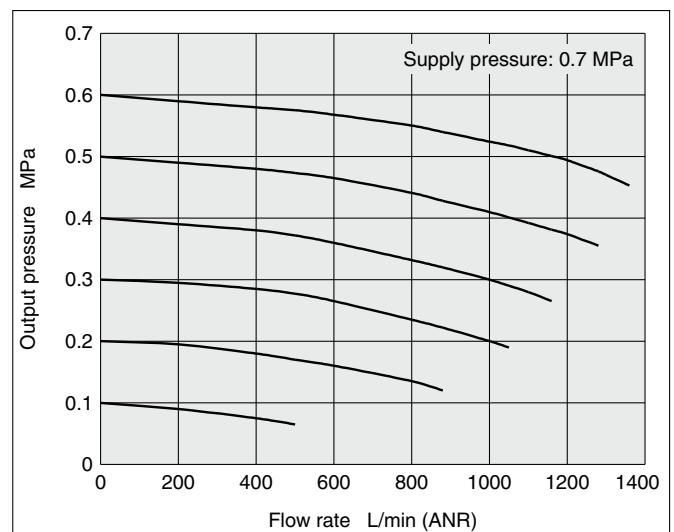

IL100 Series

Principle of Operation

IL100

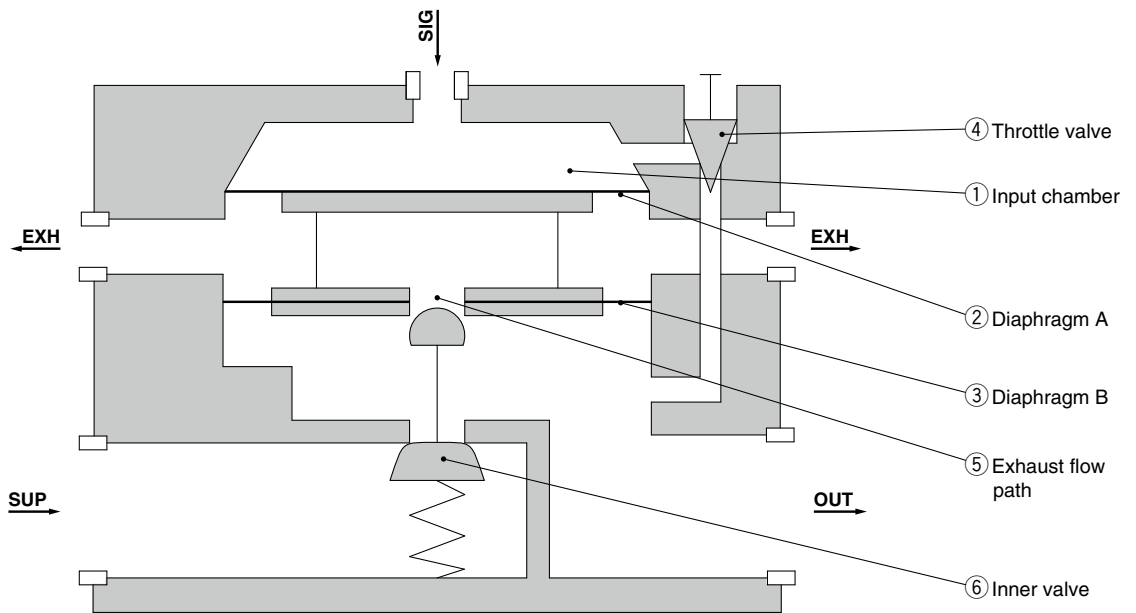

Signal pressure enters the input chamber ① from the SIG port, and acts on diaphragm A ② and exerts a downward force on diaphragm B ③. When the force of the input chamber ① exceeds the force of diaphragm B ③, inner valve ⑥ is pushed down allowing air flow out the secondary supply port. On signal pressure exhaust the supply valve closes and exhaust flow path ⑤ is opened to allow vent of the secondary air supply to atmosphere. Input and output ports are connected by a throttle valve ④. Adjustment ensures that exact equalization occurs between the signal and output supply. The above function allows a low volume signal to provide high volume output with pressure ratio remaining (1:1) for signal to output.

Construction

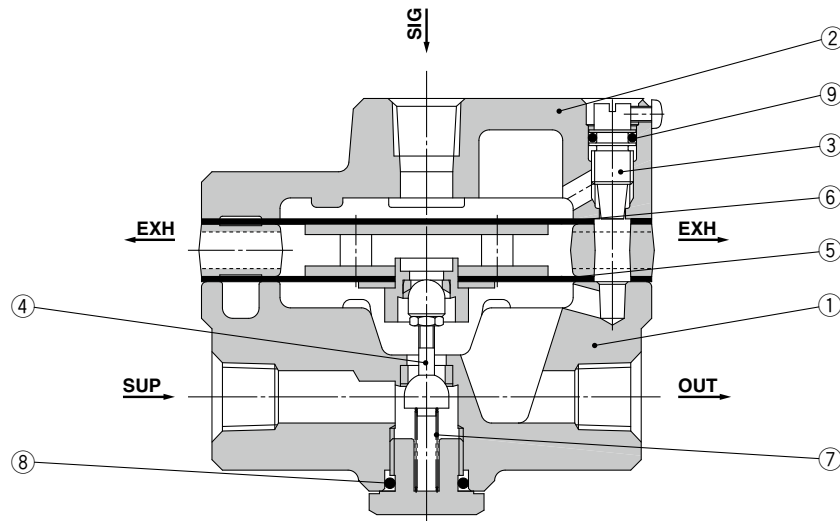

Component Parts

No.	Description	Material	Note
1	Valve	Aluminum alloy	Silver baking finish
2	Cover	Aluminum alloy	Silver baking finish
3	Throttle valve	Stainless steel	
4	Inner valve	Stainless steel	
5	Diaphragm assembly	Aluminum alloy/NBR/Resin	Chromated
6	Diaphragm	NBR	
7	Valve spring	Stainless steel	
8	O-ring	NBR	
9	O-ring	NBR	

Replacement Parts

Model	Order no.	Contents
IL100	KT-IL100	Set of left nos. ⑤, ⑥, ⑦, ⑧, ⑨

Dimensions

IL100

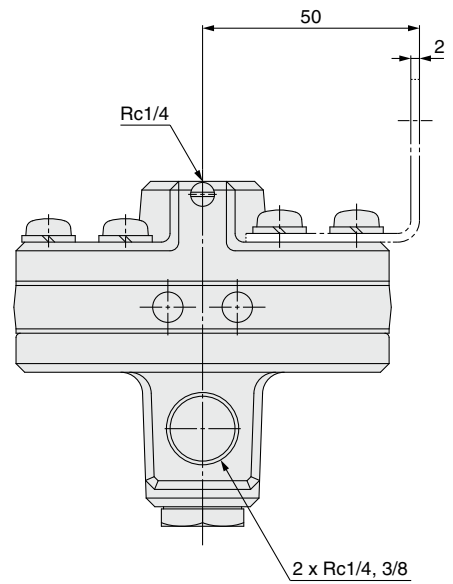
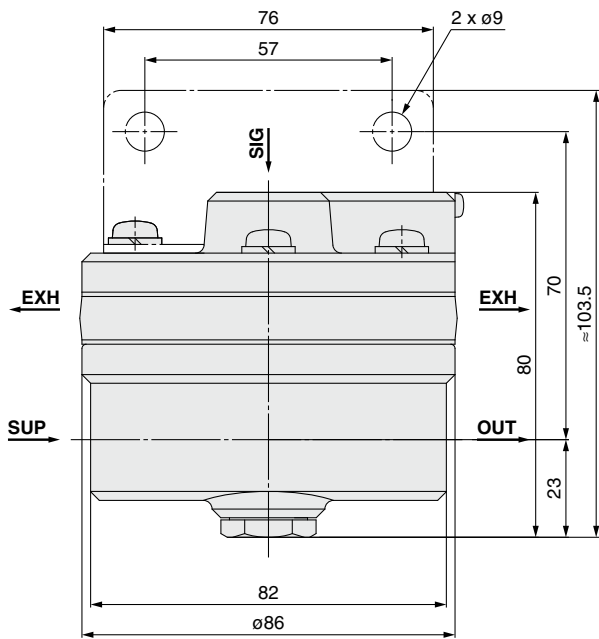

XT240 Series

Made to Order

Please contact SMC for detailed dimensions, specifications and lead times.



Large Size Booster Relay

Maximum flow rate: Approx. 6000 L/min (ANR)

How to Order

XT240-1-

Fluid temperature*

	Temperature specification
1	For general environments (-5 to 60°C)
2	For high temperature environments (-5 to 100°C)
3	For low temperature environments (-30 to 60°C)

* Please consult with SMC for -40°C specification.

Thread type

Nil	Rc
NX	NPT



Specifications

Supply pressure	Max. 1.0 MPa	
Input/Output pressure	Max. 0.7 MPa	
Air consumption	10 L/min (ANR) or less (OUT = 0.7 MPa)	
Linearity	Within ±5%	
Hysteresis	Within 2%	
Ambient and fluid temperature	For general environments	-5 to 60°C
	For high temperature environments	-5 to 100°C
	For low temperature environments	-30 to 60°C
Port size	1/4 (SIG), 1 (SUP, OUT)	
Weight	1.2 kg	

Symbol

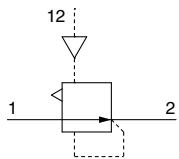

Flow Rate Characteristics

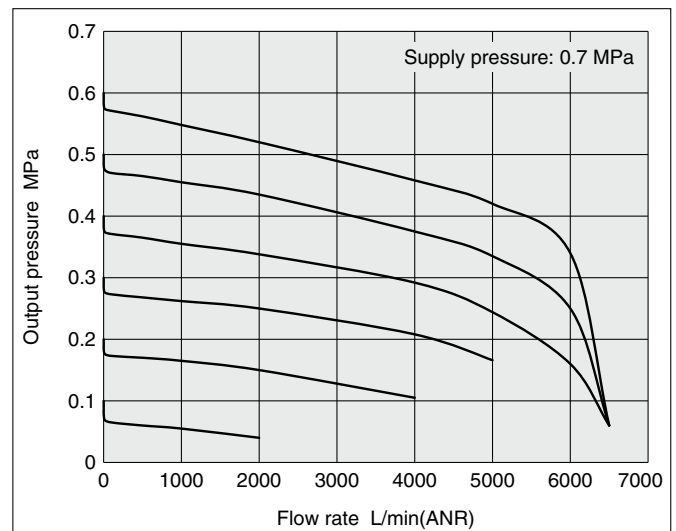

Dimensions

