

# Series 10-/11-/12- 21-/22-CXS

ø6, ø10, ø15, ø20, ø25, ø32  
Dual Rod Cylinder

## How to Order

● Clean series

10	Relief type	CXSM, CXSL
11	Vacuum suction type	CXSM, CXSL
12	Relief type (with specially treated sliding parts)	CXSL

● Dual rod cylinder

10 - CXS M 15 - 30 - Y59A

21 - CXS L 15 - 30 - Y59A

● Bearing type

L	Ball bushing bearing
M	Slide bearing

● Number of auto switches

Nil	2 pcs.
S	1 pc.
n	n pcs.

● Copper, fluorine and silicone-free + Low particle generation

21	Relief type	CXSL
22	Vacuum suction type	CXSL

● Bore size (mm)

● Port type

Symbol	Type	Bore size
Nil	M5 x 0.8	ø6 to ø20
	Rc	
TN	NPT	ø25, ø32
TF	G	

● Auto switch

Nil	Without auto switch
-----	---------------------

\* For applicable auto switches, refer to the Applicable Auto Switch.

● Cylinder stroke (mm)



## Model

Model	Bore size (mm)	Port size	Lubrication	Action	Standard stroke (mm)	Auto switch mounting	Cushion		
							Rubber	Air	
Vacuum suction type	11-/22-CXS□6	6	M5 x 0.8	Non-lube	Double acting Single rod	10, 20, 30, 40, 50	○	○ (Both sides)	-
	11-/22-CXS□10	10							
	11-/22-CXS□15	15							
	11-/22-CXS□20	20							
	11-/22-CXS□25	25							
Relief type	11-/22-CXS□32	32	1/8	Non-lube	Double acting Single rod	10, 20, 30, 40, 50, 75, 100	○	○ (Both sides)	-
	10-/12-/21-CXS□6	6							
	10-/12-/21-CXS□10	10							
	10-/12-/21-CXS□15	15							
	10-/12-/21-CXS□20	20							
	10-/12-/21-CXS□25	25							
	10-/12-/21-CXS□32	32							
			1/8			10, 20, 30, 40, 50, 75, 100			

## Specifications

Item	Bore size (mm)	6	10/15	20/25/32
Proof pressure		1.05 MPa		
Maximum operating pressure		0.7 MPa		
Minimum operating pressure		0.15 MPa	0.1 MPa	0.05 MPa
Ambient and fluid temperature		-10 to 60°C (No freezing)		
Piston speed		30 to 400 mm/s		
Stroke adjustable range		0 to -5 mm compared to the standard stroke		
Bearing type		Ball bushing bearing/Slide bearing		
Grease		10-/11-/12-: Fluorine grease 21-/22-: Lithium soap based grease		
Cleanliness class (ISO class)		10-/12-: Class 4, 21-: Class 5 11-/22-: Class 3		

## Suction Flow Rate of Vacuum Suction Type (Reference values)

Size	Suction flow rate L/min (ANR)
6	2
10	5
15	10
20/25	15
32	20

**Auto Switches (Refer to the Web Catalog for further information on auto switches.)**

Type	Special function	Electrical entry	Indicator light	Wiring (Output)	Load voltage		Auto switch model		Lead wire length (m)			Pre-wired connector	Applicable load					
					DC	AC	Perpendicular	In-line	0.5 (Nil)	3 (L)	5 (Z)		IC circuit	Relay, PLC				
Solid state auto switch	-	Grommet	Yes	3-wire (NPN)	24 V	5 V, 12 V	-	<b>Y69A</b>	<b>Y59A</b>	●	●	○	IC circuit	Relay, PLC				
				3-wire (PNP)				<b>Y7PV</b>	<b>Y7P</b>	●	●	○						
				2-wire				<b>Y69B</b>	<b>Y59B</b>	●	●	○						
				3-wire (NPN)				<b>Y7NWW</b>	<b>Y7NW</b>	●	●	○						
				3-wire (PNP)				<b>Y7PWV</b>	<b>Y7PW</b>	●	●	○						
Water resistant (2-color indicator)	-	Grommet	None	2-wire	24 V	12 V	-	<b>Y7BWW</b>	<b>Y7BW</b>	●	●	○	-	-				
								<b>**Y7BA</b>	-	●	●	○						
Reed auto switch	-	Grommet	Yes	3-wire (NPN equivalent)	24 V	12 V	-	-	<b>Z76</b>	●	●	-	IC circuit	-				
				2-wire					100 V	-	<b>Z73</b>	●			●	●	-	Relay, PLC
									100 V or less	-	<b>Z80</b>	●			●	-	IC circuit	

\*\* Water resistant type auto switches can be mounted on the above models, but in such case SMC cannot guarantee water resistance. Consult with SMC regarding water resistant types with the above model numbers.

\* Lead wire length symbols: 0.5 m ..... Nil (Example) Y59A \* Solid state auto switches marked with "○" are produced upon receipt of order.  
 3 m ..... L (Example) Y59AL  
 5 m ..... Z (Example) Y59AZ

• Auto switches are shipped together (not assembled).

**Auto Switch Proper Mounting Position (Detection at Stroke End)**

Electrical entry direction: Inward

Electrical entry direction: Outward

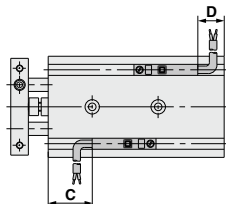
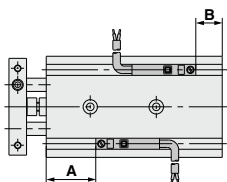

Bore size (mm)	A	B	D-Z7-Z8, D-Y7□W D-Y5□, D-Y7□		D-Y6□, D-Y7□V D-Y7□WV		D-Y7BA	
			C	D	C	D	C	D
6	20.5	4.5	16.5 (15)	0.5 (-1)	18	2	10.5	-5.5
10	27.5	7.5	23.5 (22)	3.5 (2)	25	5	17.5	-2.5
15	38	4.5	34 (32.5)	0.5 (-1)	35.5	2	28	-5.5
20	50	7	46 (44.5)	3 (1.5)	48	4.5	40	-3
25	50	9	46 (44.5)	5 (3.5)	48	6.5	40	-1
32	60	9	56 (54.5)	5 (3.5)	58	6.5	50	-1

Note 1) Negative figures in the table D indicate how much the load wires protrude from the cylinder body.  
 Note 2) ( ): Denotes the dimensions of D-Z73.  
 Note 3) Adjust the auto switch after confirming the operating conditions in the actual setting.

Basic: 10-/11-22-CXS□6, 12-21-CXSL6

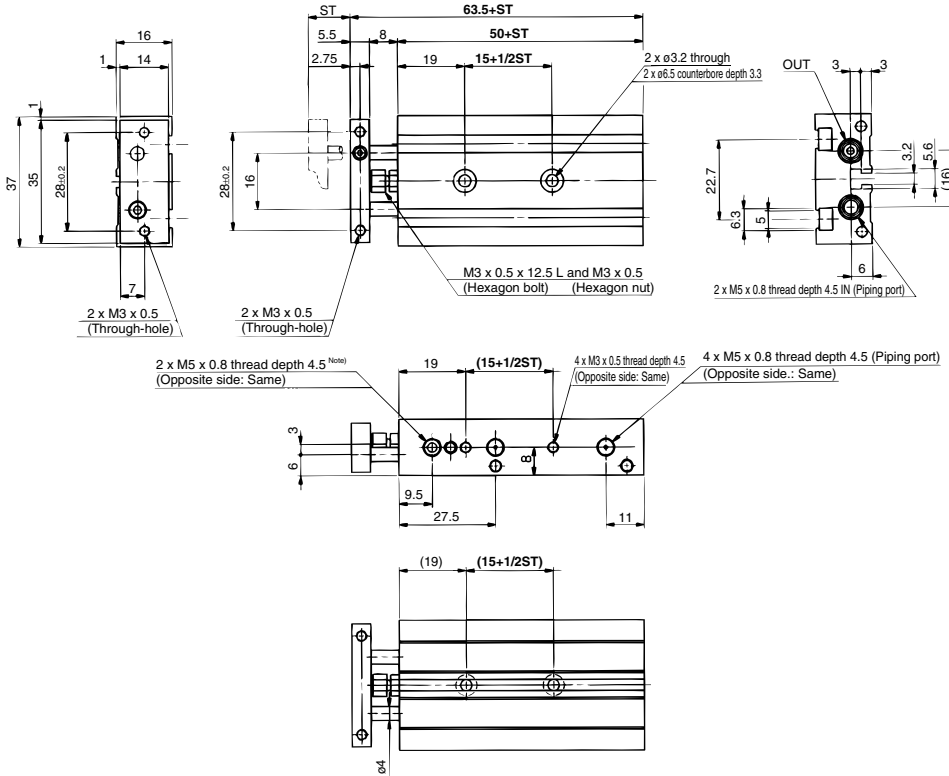

Note) 11-, 22-: Vacuum suction port Vacuum air from 2 ports on both sides.  
 10-/12-, 21-: Relief port Exhaust air from a port on one side. The port on the piston rod B side for 10-/12-, 21- is plugged since unlike the vacuum, it is not necessary to exhaust from 2 ports.

Model	15+1/2ST	50+ST	63.5+ST
10-/11-22-CXS□6-10	20	60	73.5
10-/11-22-21-CXS□6-20	25	70	83.5
10-/11-22-CXS□6-30	30	80	93.5
10-/11-22-CXS□6-40	35	90	103.5
10-/11-22-CXS□6-50	40	100	113.5

(mm)

Dual Rod Cylinder <sup>10-/11-</sup>22- **CXS**□ / <sup>12-</sup>21- **CXSL**

Basic: <sup>10-/11-</sup>22- **CXS**□10, <sup>12-</sup>21- **CXSL**10

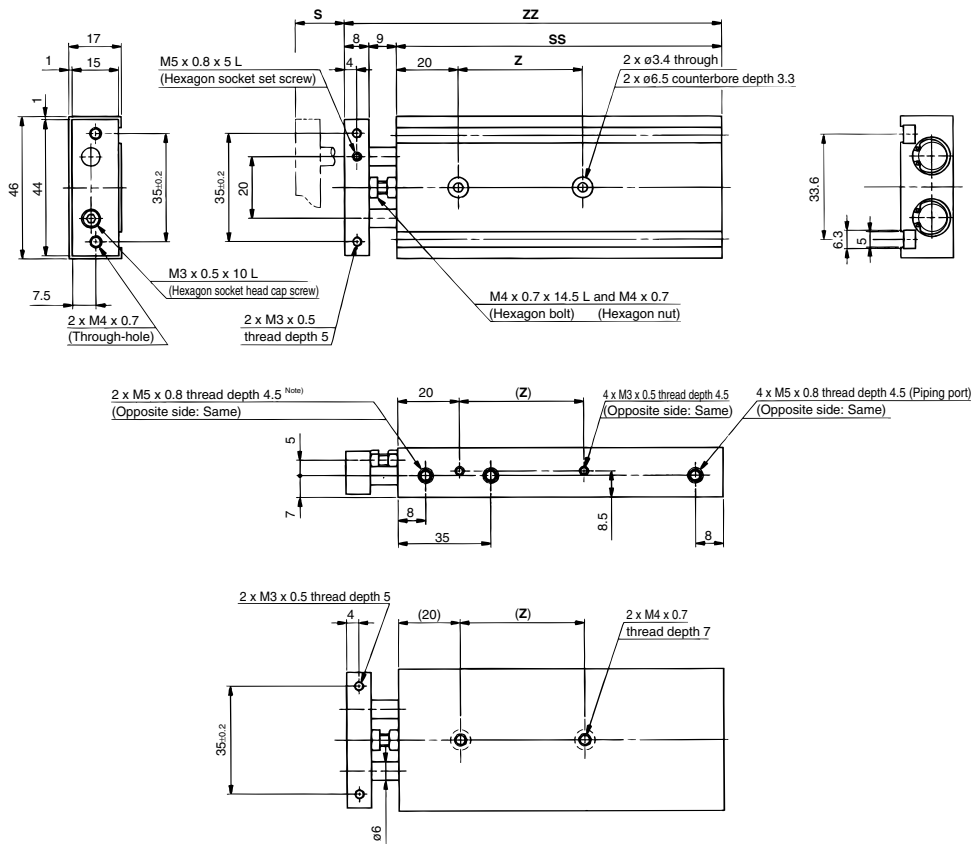

Note) 11-, 22-: Vacuum suction port Vacuum air from 2 ports on both sides.  
 10-/12-, 21-: Relief port Exhaust air from a port on one side. The port on the piston rod B side for 10-/12-, 21- is plugged since unlike the vacuum, it is not necessary to exhaust from 2 ports.

Model	S	SS	ZZ	Z
<sup>10-/11-/12-</sup> 21-22- <b>CXS</b> □10-10	10	70	87	30
<sup>10-/11-/12-</sup> 21-22- <b>CXS</b> □10-20	20	80	97	30
<sup>10-/11-/12-</sup> 21-22- <b>CXS</b> □10-30	30	90	107	40
<sup>10-/11-/12-</sup> 21-22- <b>CXS</b> □10-40	40	100	117	40
<sup>10-/11-/12-</sup> 21-22- <b>CXS</b> □10-50	50	110	127	40

Basic: 10-/11-22-CXS□15, 12-/21-CXSL15

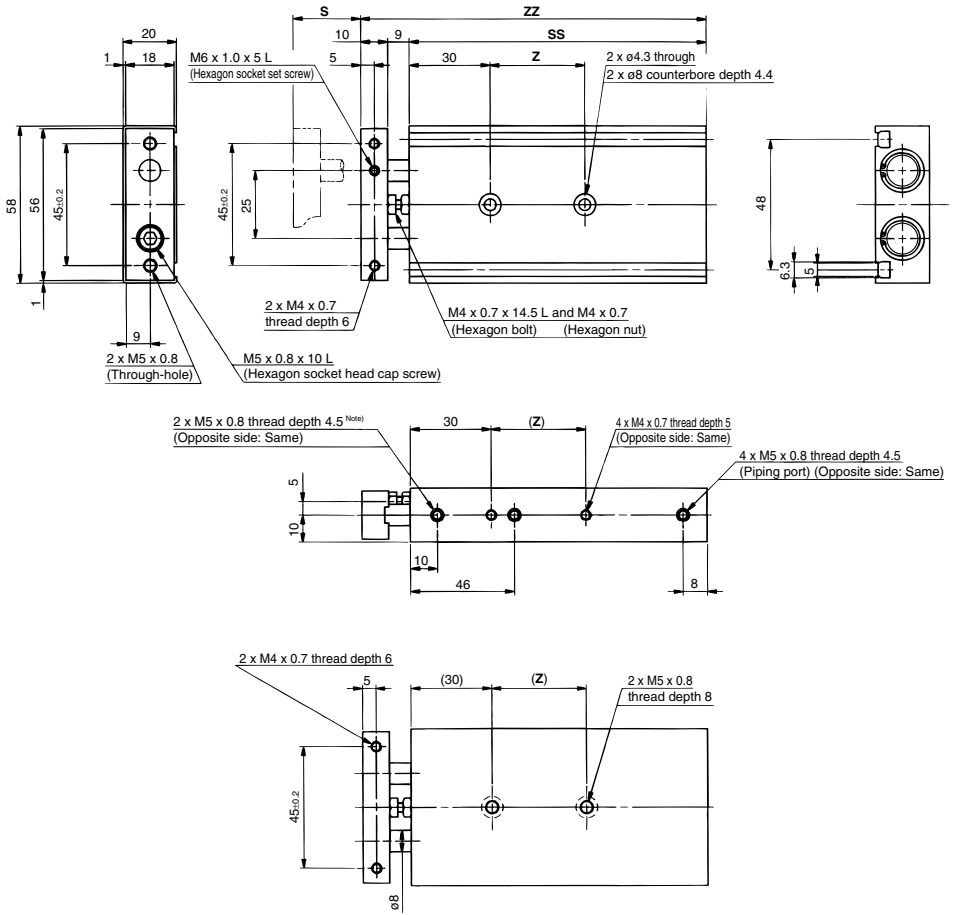

Note) 11-, 22-: Vacuum suction port Vacuum air from 2 ports on both sides.  
 10-/12-, 21-: Relief port Exhaust air from a port on one side. The port on the piston rod B side for 10-/12-, 21- is plugged since unlike the vacuum, it is not necessary to exhaust from 2 ports.

Model	S	SS	ZZ	Z
10-/11-12-21-22-CXS□15-10	10	77.5	96.5	25
10-/11-12-21-22-CXS□15-20	20	87.5	106.5	25
10-/11-12-21-22-CXS□15-30	30	97.5	116.5	35
10-/11-12-21-22-CXS□15-40	40	107.5	126.5	35
10-/11-12-21-22-CXS□15-50	50	117.5	136.5	45

- Directional Control Valves
- Air Cylinders
- Rotary Actuators
- Air Grippers
- Air Preparation Equipment
- Modular F. R.
- Pressure Control Equipment
- Fittings & Tubing
- Flow Control Equipment
- Pressure Switches/ Pressure Sensors

Dual Rod Cylinder <sup>10/-11-</sup>22-CXS□ / <sup>12-</sup>21-CXSL

Basic: <sup>10/-11-</sup>22-CXS□20, <sup>12-</sup>21-CXSL20

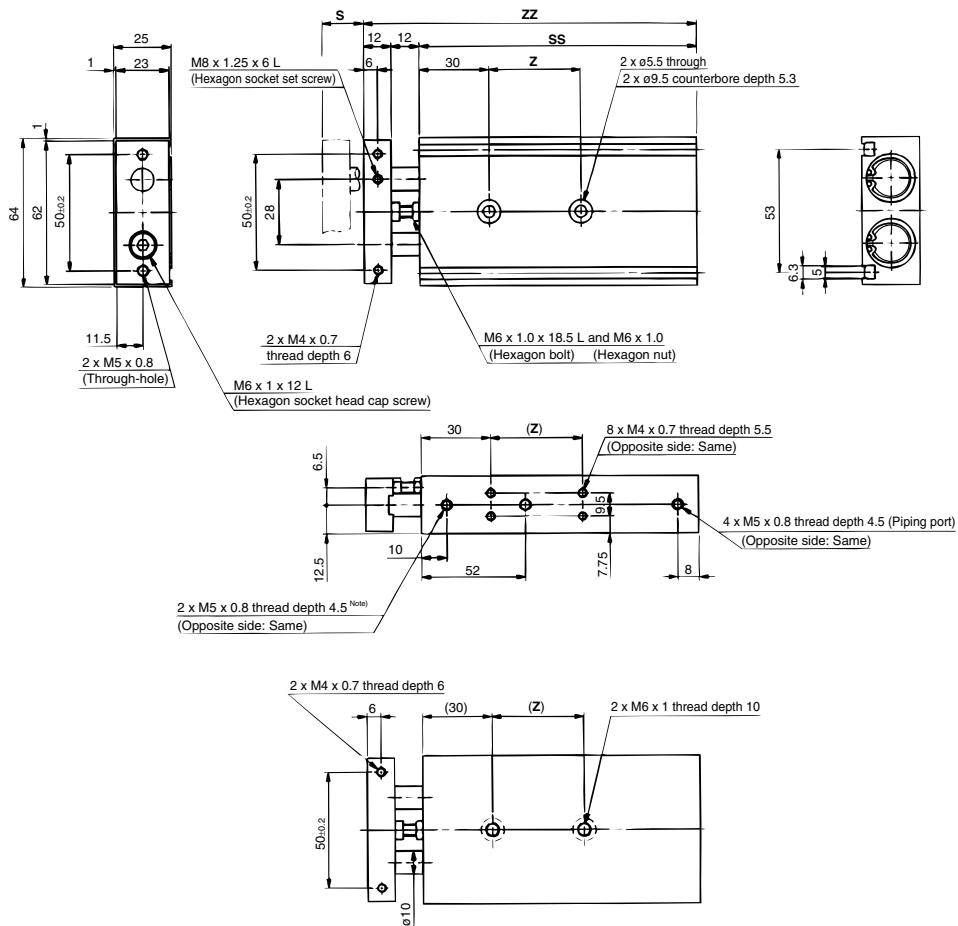

Note) 11-, 22-: Vacuum suction port Vacuum air from 2 ports on both sides.  
 10-/12-, 21-: Relief port Exhaust air from a port on one side. The port on the piston rod B side for 10-/12-, 21- is plugged since unlike the vacuum, it is not necessary to exhaust from 2 ports.

(mm)

Model	S	SS	ZZ	Z
<sup>10-</sup> 11-22-CXS□20-10	10	92	116	30
<sup>10-/11-</sup> 12-21-22-CXS□20-20	20	102	126	40
<sup>10-/11-</sup> 12-21-22-CXS□20-30	30	112	136	40
<sup>10-/11-</sup> 12-21-22-CXS□20-40	40	122	146	40
<sup>10-</sup> 11-22-CXS□20-50	50	132	156	60
<sup>10-/11-</sup> 12-21-22-CXS□20-75	75	157	181	60
<sup>10-/11-</sup> 12-21-22-CXS□20-100	100	182	206	80

Basic: 10-/11-22-**CXS**□25, 12-21-**CXSL**25

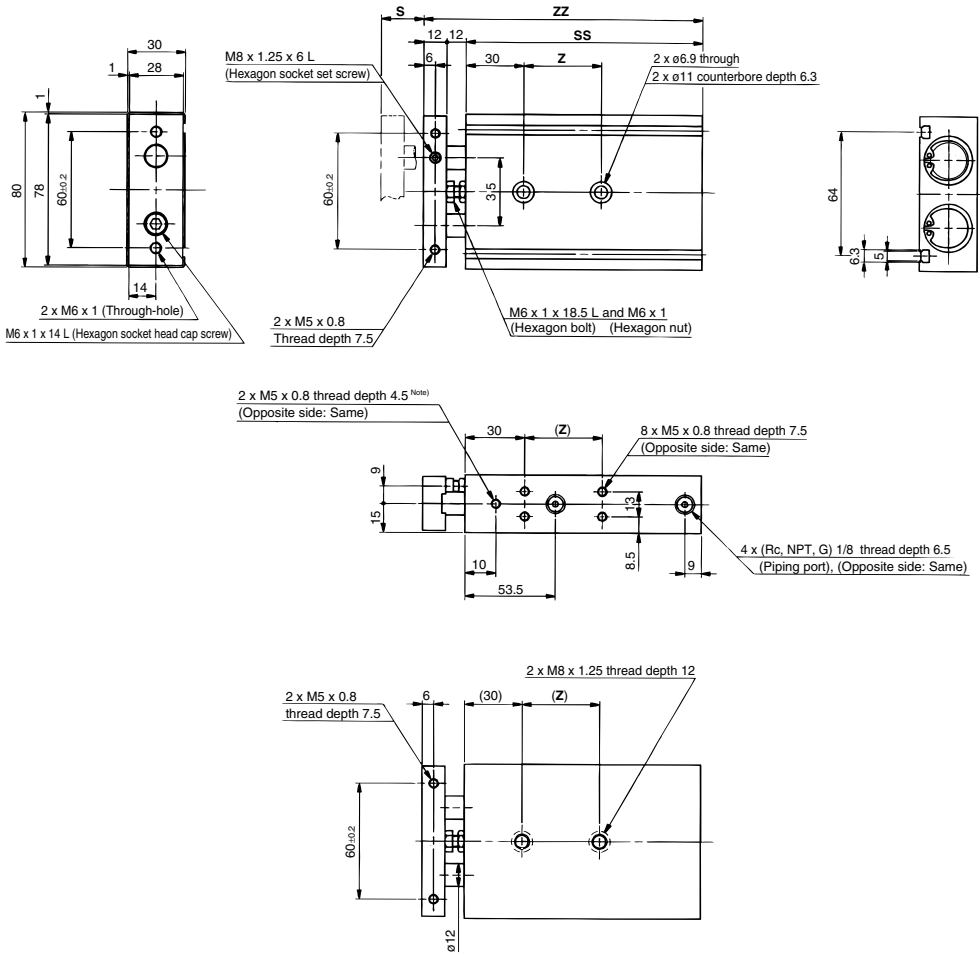

Note) 11-, 22-: Vacuum suction port Vacuum air from 2 ports on both sides.  
 10-/12-, 21-: Relief port Exhaust air from a port on one side. The port on the piston rod B side for 10-/12-, 21- is plugged since unlike the vacuum, it is not necessary to exhaust from 2 ports.

Model	S	SS	ZZ	Z	(mm)
10-11-22- <b>CXS</b> □25-10	10	94	118	30	
10-11-12-21-22- <b>CXS</b> □25-20	20	104	128	40	
10-11-12-21-22- <b>CXS</b> □25-30	30	114	138	40	
10-11-12-21-22- <b>CXS</b> □25-40	40	124	148	40	
10-11-12-21-22- <b>CXS</b> □25-50	50	134	158	60	
10-11-12-21-22- <b>CXS</b> □25-75	75	159	183	60	
10-11-12-21-22- <b>CXS</b> □25-100	100	184	208	80	

Directional Control Valves

Air Cylinders

Rotary Actuators

Air Grippers

Air Preparation Equipment

Modular F. R.

Pressure Control Equipment

Fittings & Tubing

Flow Control Equipment

Pressure Switches/ Pressure Sensors

Dual Rod Cylinder <sup>10-/11-</sup>22-CXS□/ <sup>12-</sup>21-CXSL

Basic: <sup>10-/11-</sup>22-CXS□32, <sup>12-</sup>21-CXSL32

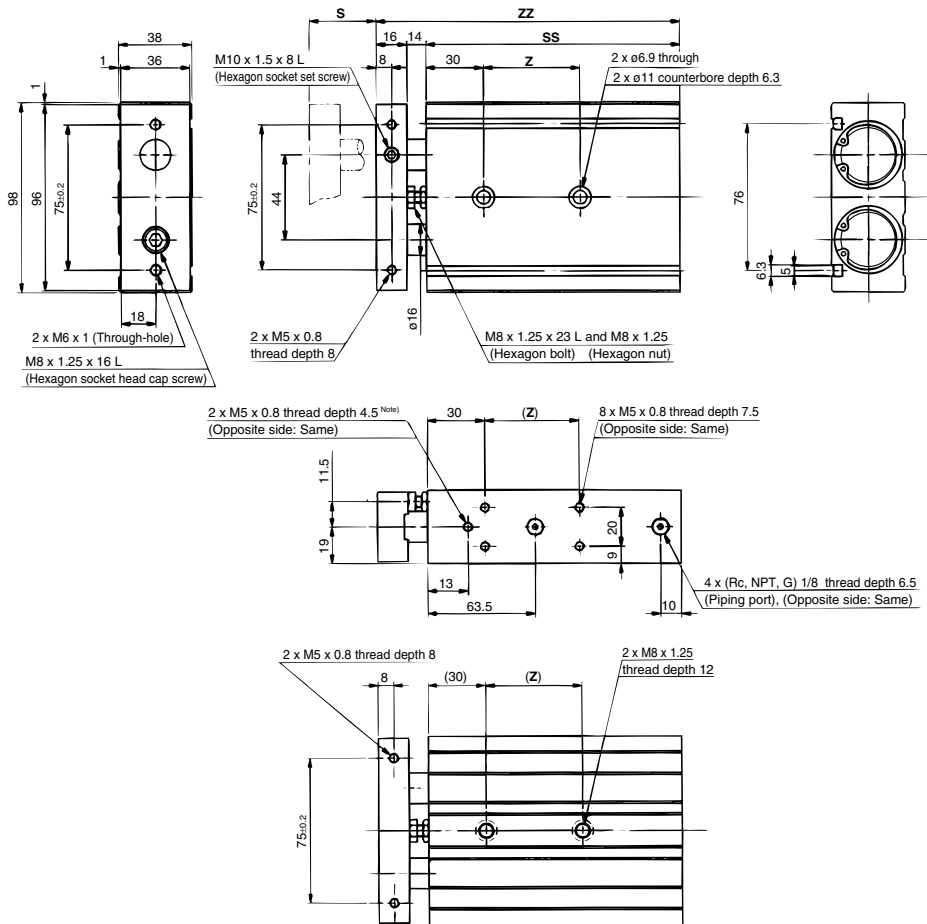

Note) 11-, 22-: Vacuum suction port Vacuum air from 2 ports on both sides.  
 10-/12-, 21-: Relief port Exhaust air from a port on one side. The port on the piston rod B side for 10-/12-, 21- is plugged since unlike the vacuum, it is not necessary to exhaust from 2 ports.

(mm)

Model	S	SS	ZZ	Z
<sup>10-</sup> 21-22 CXS□32-10	10	104	134	40
<sup>10-</sup> 21-22 CXS□32-20	20	114	144	50
<sup>10-/11-</sup> 21-22 CXS□32-30	30	124	154	50
<sup>10-</sup> 21-22 CXS□32-40	40	134	164	50
<sup>10-</sup> 21-22 CXS□32-50	50	144	174	60
<sup>10-/11-12-</sup> 21-22 CXS□32-75	75	169	199	70
<sup>10-</sup> 21-22 CXS□32-100	100	194	224	90



## ⚠ Specific Product Precautions

Be sure to read this before handling.

### Mounting

#### ⚠ Caution

- Make sure that the surface on which the cylinder is to be mounted is flat (reference value for flatness: 0.05 or less).**  
Dual rod cylinders can be mounted from 3 directions, however, make sure that the surface on which the cylinder is to be mounted is flat (reference value for flatness: 0.05 or less). Otherwise, the accuracy of the piston rod operation is not achieved, and malfunction may occur.
- The piston rod must be retracted when mounting the cylinder.**  
Scratches or gouges in the piston rod may lead to damaged bearings and seals, and causes malfunction or air leakage.
- Secure the plate before mounting the load.**  
Load mounting without securing the plate may cause galling of the piston rod, leading to particle generation.

### Piping

#### ⚠ Caution

- Plug the appropriate supply port(s) according to the operating state.**  
Dual rod cylinders have 2 supply ports for each operating direction (3 supply ports for ø6 only). Plug the appropriate supply port according to the operating state. After the plugged port has been changed, check the port for air leakage. If small leakage is detected, unplug the port, check the seat surface, and reassemble it.
- For 12- relief port, change the plug position according to the operating state.**  
A relief port is provided on each side. Change the plug position according to the operating state. After the change, apply 0.1 MPa pressure from the relief port to check the plugged portion for air leakage. If small leakage is detected, unplug the port, check the seat surface, and reassemble it.
- Vacuum air from vacuum ports on both sides of 11- and 22-.**  
Vacuum from one side is insufficient. Be sure to vacuum simultaneously from both sides.

### Stroke Adjustment

#### ⚠ Caution

- After adjusting the stroke, tighten firmly the hexagon nut to prevent it from loosening.**  
Dual rod cylinders have a bolt to adjust 0 to -5 mm strokes on the retracted end (IN).  
Loosen the hexagon nut to adjust the stroke. However, make sure to tighten the hexagon nut after making an adjustment.
- Do not operate a cylinder with its bumper bolt removed.**  
If the bumper bolt is removed, the piston hits the head cover, causing damage to the cylinder. Therefore, do not use a cylinder without a bumper bolt.
- A bumper at the end of the bumper bolt is replaceable. In case a missing bumper, or a bumper has a permanent setting, use the following part numbers for ordering.**

Model	CXS6/10/15	CXS20/25	CXS32
Part number	CXS10-34A 28747	CXS20-34A 28749	CXS32-34A 28751
No. of bumpers	1		

### Disassembly and Maintenance

#### ⚠ Caution

- Never use a cylinder with its plate removed.**  
When removing the hexagon socket head cap screw from the end plate, the piston rod must be secured to prevent rotation. However, if the sliding parts of the piston rod are scratched or gouged, malfunction may occur. If a plate is not required for your applications, use the cylinder that does not come with a plate, available through Made to Order (-X593).
- When disassembling and reassembling the cylinder, contact SMC or refer to the separate operation manual.**

#### ⚠ Warning

- Take precautions when your hands are near the plate and housing.**  
During cylinder operation, be careful not to get your hand or fingers caught between the plate and housing.