

25A- Series

Applicable Auto Switches

Applicable Cylinder Series

Auto switches						Air cylinders																
Type	Special function	Electrical entry	Indicator light	Wiring (Output)	Electrical entry direction	Auto switch model	Lead wire length [m]				Pre-wired connector	CDJP2	CD(B)J2 CDJ2K	CD85	CDM2	CD(B)G1	MDB	C(P)96SD	CDA2	CDS2		
							0.5 Nil	1 M	3 L	5 Z											ø4 to ø16 SDPC	ø10, ø16
Solid state auto switch	—	Grommet	Yes	3-wire (NPN)	In-line	D-M9N-900	●	●	●	○	—	●	●	●	●	●	—	●	●	●		
						3-wire (PNP)	D-M9P-900	●	●	●	○	—	●	●	●	●	●	—	●	●	●	●
						2-wire	D-M9B-900	●	●	●	○	—	●	●	●	●	●	—	●	●	●	●
				3-wire (NPN)	Perpendicular	D-M9NV-900	●	●	●	○	—	●	●	●	●	●	—	●	●	●	●	
						3-wire (PNP)	D-M9PV-900	●	●	●	○	—	●	●	●	●	●	—	●	●	●	●
						2-wire	D-M9BV-900	●	●	●	○	—	●	●	●	●	●	—	●	●	●	●
				3-wire (NPN)	In-line	D-M9NW-900	●	●	●	○	—	●	●	●	●	●	—	●	●	●	●	●
						3-wire (PNP)	D-M9PW-900	●	●	●	○	—	●	●	●	●	●	—	●	●	●	●
						2-wire	D-M9BW-900	●	●	●	○	○	●	●	●	●	●	—	●	●	●	●
				3-wire (NPN)	Perpendicular	D-M9N WV-900	●	●	●	○	—	●	●	●	●	●	—	●	●	●	●	●
						3-wire (PNP)	D-M9P WV-900	●	●	●	○	—	●	●	●	●	●	—	●	●	●	●
						2-wire	D-M9B WV-900	●	●	●	○	○	●	●	●	●	●	—	●	●	●	●
	3-wire (NPN)	In-line	D-Y59A-900	●	—	●	○	—	—	—	—	—	—	—	—	—	—	—	—			
			3-wire (PNP)	D-Y7P-900	●	—	●	○	—	—	—	—	—	—	—	—	—	—	—			
			2-wire	D-Y59B-900	●	—	●	○	—	—	—	—	—	—	—	—	—	—	—			
	3-wire (NPN)	Perpendicular	D-Y69A-900	●	—	●	○	—	—	—	—	—	—	—	—	—	—	—	—			
			3-wire (PNP)	D-Y7PV-900	●	—	●	○	—	—	—	—	—	—	—	—	—	—	—			
			2-wire	D-Y69B-900	●	—	●	○	—	—	—	—	—	—	—	—	—	—	—			
	3-wire (NPN)	In-line	D-Y7NW-900	●	—	●	○	—	—	—	—	—	—	—	—	—	—	—	—			
			3-wire (PNP)	D-Y7PW-900	●	—	●	○	—	—	—	—	—	—	—	—	—	—	—			
			2-wire	D-Y7BW-900	●	—	●	○	—	—	—	—	—	—	—	—	—	—	—			
	3-wire (NPN)	Perpendicular	D-Y7N WV-900	●	—	●	○	—	—	—	—	—	—	—	—	—	—	—	—			
			3-wire (PNP)	D-Y7P WV-900	●	—	●	○	—	—	—	—	—	—	—	—	—	—	—			
			2-wire	D-Y7B WV-900	●	—	●	○	—	—	—	—	—	—	—	—	—	—	—			
	3-wire (NPN)	In-line	D-G59-900	●	—	●	○	—	—	—	—	—	—	—	—	—	●	—	—			
			3-wire (PNP)	D-G5P-900	●	—	●	○	—	—	—	—	—	—	—	—	●	—	—			
			2-wire	D-K59-900	●	—	●	○	—	—	—	—	—	—	—	—	●	—	—			
			3-wire (NPN)	D-G59W-900	●	—	●	○	—	—	—	—	—	—	—	—	●	—	—			
			3-wire (PNP)	D-G5PW-900	●	—	●	○	—	—	—	—	—	—	—	—	●	—	—			
			2-wire	D-K59W-900	●	—	●	○	○	—	—	—	—	—	—	—	●	—	—			
	3-wire (NPN)	In-line	D-F79-900	●	—	●	○	—	—	—	—	—	—	—	—	—	—	—	—			
			3-wire (PNP)	D-F7P-900	●	—	●	○	—	—	—	—	—	—	—	—	—	—	—			
			2-wire	D-J79-900	●	—	●	○	—	—	—	—	—	—	—	—	—	—	—			
	3-wire (NPN)	Perpendicular	D-F7NV-900	●	—	●	○	—	—	—	—	—	—	—	—	—	—	—	—			
			3-wire (PNP)	D-F7PV-900	●	—	●	○	—	—	—	—	—	—	—	—	—	—	—			
			2-wire	D-F7BV-900	●	—	●	○	—	—	—	—	—	—	—	—	—	—	—			
	3-wire (NPN)	In-line	D-F79W-900	●	—	●	○	—	—	—	—	—	—	—	—	—	—	—	—			
			3-wire (PNP)	D-F7PW-900	●	—	●	○	—	—	—	—	—	—	—	—	—	—	—			
			2-wire	D-J79W-900	●	—	●	○	—	—	—	—	—	—	—	—	—	—	—			
	3-wire (NPN)	Perpendicular	D-F7N WV-900	●	—	●	○	—	—	—	—	—	—	—	—	—	—	—	—			
			3-wire (PNP)	D-F7P WV-900	●	—	●	○	—	—	—	—	—	—	—	—	—	—	—			
			2-wire	D-F7B WV-900	●	—	●	○	—	—	—	—	—	—	—	—	—	—	—			
	3-wire (NPN)	In-line	D-F8N-900	●	—	●	○	—	—	—	—	—	—	—	—	—	—	—	—			
			3-wire (PNP)	D-F8P-900	●	—	●	○	—	—	—	—	—	—	—	—	—	—	—			
			2-wire	D-F8B-900	●	—	●	○	—	—	—	—	—	—	—	—	—	—	—			
	Reed auto switch	—	Grommet	Yes	2-wire	In-line	D-A93L-900	—	—	●	—	—	●*1	●	—	●	●	—	●	●		
							D-A90L-900	—	—	●	—	—	●*1	●	—	●	●	—	●	●	●	
							D-Z80-900	—	—	●	—	—	—	—	—	—	—	—	—	—	—	—
3-wire (NPN equiv.)		In-line	D-E76A	●	—	●	—	—	—	—	—	—	—	—	—	—	—	—				
			D-E73A	●	—	●	—	—	—	—	—	—	—	—	—	—	—	—				
			D-E80A	●	—	●	—	—	—	—	—	—	—	—	—	—	—	—				

*1 The D-A90L-900 and D-A93L-900 cannot be mounted on ø4. * Solid state auto switches marked with a “○” are produced upon receipt of order.

Ordering the Auto Switches

Please be aware that the order part numbers for the cylinder mounted and individual auto switches are different.

(Example) Part number for ordering D-M9BWL-900:

- Cylinder mounted type: 25A-CDJ2L16-60Z-M9BWL-B
(Omit the first "D-" and the last "-900" or "-901".)
- Individual auto switch: D-M9BWL-900
(Place the order with the part number for auto switch shown in the table above.)

- Lead wire length symbols: 0.5 m..... Nil (Example) M9NW
- 1 m..... M (Example) M9NWM
- 3 m..... L (Example) M9NWL
- 5 m..... Z (Example) M9NWZ

25A- Series

Applicable Cylinder Series

Auto switches													
Type	Special function	Electrical entry	Indicator light	Wiring (Output)	Electrical entry direction	Auto switch model	Lead wire length [m]				Pre-wired connector		
							0.5	1	3	5			
							Nil	M	L	Z	SDPC		
Solid state auto switch	—	Grommet	Yes	3-wire (NPN)	In-line	D-M9N-900	●	●	●	○	—		
				3-wire (PNP)		D-M9P-900	●	●	●	○	—		
				2-wire	Perpendicular	D-M9B-900	●	●	●	○	—		
				3-wire (NPN)		D-M9NV-900	●	●	●	○	—		
				3-wire (PNP)	D-M9PV-900	●	●	●	○	—			
				2-wire	D-M9BV-900	●	●	●	○	—			
				3-wire (NPN)	In-line	D-M9NW-900	●	●	●	○	—		
				3-wire (PNP)		D-M9PW-900	●	●	●	○	—		
				2-wire	Perpendicular	D-M9BW-900	●	●	●	○	○		
				3-wire (NPN)		D-M9NWV-900	●	●	●	○	—		
	3-wire (PNP)			D-M9PWV-900	●	●	●	○	—				
	2-wire			D-M9BWB-900	●	●	●	○	○				
	—			Diagnostic indication (2-color indicator)	3-wire (NPN)	In-line	D-Y59A-900	●	—	●	○	—	
					3-wire (PNP)		D-Y7P-900	●	—	●	○	—	
					2-wire	Perpendicular	D-Y59B-900	●	—	●	○	—	
					3-wire (NPN)		D-Y69A-900	●	—	●	○	—	
					3-wire (PNP)	D-Y7PV-900	●	—	●	○	—		
					2-wire	D-Y69B-900	●	—	●	○	—		
					3-wire (NPN)	In-line	D-Y7NW-900	●	—	●	○	—	
					3-wire (PNP)		D-Y7PW-900	●	—	●	○	—	
		2-wire			Perpendicular	D-Y7BW-900	●	—	●	○	—		
		3-wire (NPN)				D-Y7NWV-900	●	—	●	○	—		
	3-wire (PNP)	D-Y7PWV-900		●	—	●	○	—					
	2-wire	D-Y7BWB-900		●	—	●	○	—					
	—	Diagnostic indication (2-color indicator)		3-wire (NPN)	In-line	D-G59-900	●	—	●	○	—		
				3-wire (PNP)		D-G5P-900	●	—	●	○	—		
				2-wire	Perpendicular	D-K59-900	●	—	●	○	—		
				3-wire (NPN)		D-G59W-900	●	—	●	○	—		
				3-wire (PNP)	D-G5PW-900	●	—	●	○	—			
				2-wire	D-K59W-900	●	—	●	○	○			
				—	Diagnostic indication (2-color indicator)	3-wire (NPN)	In-line	D-F79-900	●	—	●	○	—
						3-wire (PNP)		D-F7P-900	●	—	●	○	—
						2-wire	Perpendicular	D-J79-900	●	—	●	○	—
						3-wire (NPN)		D-F7NV-900	●	—	●	○	—
	3-wire (PNP)	D-F7PV-900				●	—	●	○	—			
	2-wire	In-line				D-F7BV-900	●	—	●	○	—		
	3-wire (NPN)					D-F79W-900	●	—	●	○	—		
	3-wire (PNP)	D-F7PW-900				●	—	●	○	—			
	2-wire	Perpendicular				D-J79W-900	●	—	●	○	—		
	3-wire (NPN)					D-F7NWV-900	●	—	●	○	—		
2-wire	D-F7BWB-900	●	—	●	○	—							
Reed auto switch	—	Grommet	Yes	2-wire	In-line	D-A93L-900	—	—	●	—	—		
			No			D-A90L-900	—	—	●	—	—		
			—	Yes	3-wire (NPN equiv.)	In-line	D-E76A	●	—	●	—	—	
				No	2-wire		D-E73A	●	—	●	—	—	
	—		Diagnostic indication (2-color indicator)	3-wire (NPN)	Perpendicular	D-F8N-900	●	—	●	○	—		
				3-wire (PNP)		D-F8P-900	●	—	●	○	—		
				2-wire	D-F8B-900	●	—	●	○	—			
				—	—	—	—	—	—	—	—	—	

25A- Series

Applicable Rotary Actuator Series

Type	Special function	Electrical entry	Indicator light	Auto switches					Rotary actuators								
				Wiring (Output)	Electrical entry direction	Auto switch model	Lead wire length [m]				Pre-wired connector	MSQA MSQB	MSQ MSZ	MDSUB			
							0.5 Nil	1 M	3 L	5 Z				10 to 200	10 to 50	1, 3	7, 20
Solid state auto switch	—	Grommet	Yes	3-wire (NPN)	In-line	D-M9N-900	●	●	●	○	—	●	●	—	—		
						D-M9P-900	●	●	●	○	—	●	●	—	—		
						2-wire	D-M9B-900	●	●	●	○	—	●	●	—	—	
						3-wire (NPN)	Perpendicular	D-M9NV-900	●	●	●	○	—	●	●	—	—
								D-M9PV-900	●	●	●	○	—	●	●	—	—
						2-wire	D-M9BV-900	●	●	●	○	—	●	●	—	—	
				3-wire (PNP)	In-line	D-M9NW-900	●	●	●	○	—	●	●	—	—		
						D-M9PW-900	●	●	●	○	—	●	●	—	—		
						2-wire	D-M9BW-900	●	●	●	○	○	●	●	—	—	
						3-wire (NPN)	Perpendicular	D-M9NWV-900	●	●	●	○	—	●	●	—	—
								D-M9PWV-900	●	●	●	○	—	●	●	—	—
						2-wire	D-M9BWV-900	●	●	●	○	○	●	●	—	—	
	3-wire (NPN)	In-line	D-Y59A-900	●	—	●	○	—	—	—	—	—					
			D-Y7P-900	●	—	●	○	—	—	—	—	—					
			2-wire	D-Y59B-900	●	—	●	○	—	—	—	—					
			3-wire (NPN)	Perpendicular	D-Y69A-900	●	—	●	○	—	—	—	—				
					D-Y7PV-900	●	—	●	○	—	—	—	—				
			2-wire	D-Y69B-900	●	—	●	○	—	—	—	—					
	Diagnostic indication (2-color indicator)	3-wire (NPN)	In-line	D-Y7NW-900	●	—	●	○	—	—	—	—					
				D-Y7PW-900	●	—	●	○	—	—	—	—					
				2-wire	D-Y7BW-900	●	—	●	○	—	—	—	—				
				3-wire (NPN)	Perpendicular	D-Y7NWV-900	●	—	●	○	—	—	—	—			
						D-Y7PWV-900	●	—	●	○	—	—	—	—			
				2-wire	D-Y7BWV-900	●	—	●	○	—	—	—	—				
		3-wire (PNP)	In-line	D-S991-901*1	●	—	●	○	—	—	—	●	—				
				D-S992-901*1	●	—	●	○	—	—	—	●	—				
				D-S9P1-901*1	●	—	●	○	—	—	—	●	—				
				D-S9P2-901*1	●	—	●	○	—	—	—	●	—				
				D-T991-901*1	●	—	●	○	—	—	—	●	—				
				D-T992-901*1	●	—	●	○	—	—	—	●	—				
	3-wire (NPN)	Perpendicular	D-S99V1-901*1	●	—	●	○	—	—	—	●	—					
			D-999V2-901*1	●	—	●	○	—	—	—	●	—					
			D-S9PV1-901*1	●	—	●	○	—	—	—	●	—					
			D-S9PV2-901*1	●	—	●	○	—	—	—	●	—					
			D-T99V1-901*1	●	—	●	○	—	—	—	●	—					
			D-T99V2-901*1	●	—	●	○	—	—	—	●	—					
	3-wire (PNP)	In-line	D-S791-901*1	●	—	●	○	—	—	—	—	●					
			D-S792-901*1	●	—	●	○	—	—	—	—	●					
			D-S7P1-901*1	●	—	●	○	—	—	—	—	●					
			D-S7P2-901*1	●	—	●	○	—	—	—	—	●					
D-T791-901*1			●	—	●	○	—	—	—	—	●						
D-T792-901*1			●	—	●	○	—	—	—	—	●						
Reed auto switch	—	Grommet	Yes	2-wire	In-line	D-A93L-900	—	—	●	—	—	●	●	—	—		
						D-A90L-900	—	—	●	—	—	●	●	—	—		

- * Solid state auto switches marked with a "○" are produced upon receipt of order.
- * Note that the individual auto switch with part number of "S□□" and "T□□" have the right-hand-type (□□□1) and the left-hand-type (□□□2).
When you order the actuator with two auto switches at the part number of the actuator, one each of the right-hand-type and the left-hand-type are shipped together with the actuator.
- * When the MHZ2-10, MHZL2-10, MHL2-10 to 40, or MHS3-32 air gripper is ordered with auto switch, mounting brackets are supplied with the air gripper.
When the auto switch is used at the square groove on the side with other cylinder bore sizes, or ordering only auto switches separately, mounting brackets (90-BMG2-012) are required. Order them separately. For details, refer to page 325.

Ordering the Auto Switches

Please be aware that the order part numbers for the rotary actuator mounted and individual auto switches are different.
 (Example) Part number for ordering D-M9BWL-900:

- Rotary actuator mounted type: 25A-MSQB-10A-M9BWL
- Individual auto switch: D-M9BWL-900
(Place the order with the part number for auto switch shown in the table above.)

* Lead wire length symbols: 0.5 m..... Nil (Example) M9NW
 1 m..... M (Example) M9NWM
 3 m..... L (Example) M9NWL
 5 m..... Z (Example) M9NWZ

*1 Lead wire for a solid state auto switch with "-901" at the end of part number has been changed to a cable for a robot use.

Applicable Air Gripper Series

Type	Special function	Electrical entry	Indicator light	Auto switches					Air grippers											
				Wiring (Output)	Electrical entry direction	Auto switch model	Lead wire length [m]				Pre-wired connector	JMHZ2	JMHZ2-X6900	JMHZ2-X7460	MHZ2	MHZL2	MHZJ2	MHZJ2-X6100	MHZL2-X5955	
							0.5 Nil	1 M	3 L	5 Z										SDPC
Solid state auto switch	—	Grommet	Yes	In-line	In-line	D-M9N-900	●	●	●	○	—	●	●	●	●	●	●	●		
						D-M9P-900	●	●	●	○	—	●	●	●	●	●	●	●	●	
						D-M9B-900	●	●	●	○	—	●	●	●	●	●	●	●	●	
						Perpendicular	D-M9NV-900	●	●	●	○	—	●	●	●	●	●	●	●	●
							D-M9PV-900	●	●	●	○	—	●	●	●	●	●	●	●	●
							D-M9BV-900	●	●	●	○	—	●	●	●	●	●	●	●	●
				In-line	D-M9NW-900	●	●	●	○	—	●	●	●	●	●	●	●	●		
					D-M9PW-900	●	●	●	○	—	●	●	●	●	●	●	●	●		
					D-M9BW-900	●	●	●	○	○	●	●	●	●	●	●	●	●		
					Perpendicular	D-M9NWV-900	●	●	●	○	—	●	●	●	●	●	●	●	●	
						D-M9PwV-900	●	●	●	○	—	●	●	●	●	●	●	●	●	
						D-M9BwV-900	●	●	●	○	○	●	●	●	●	●	●	●	●	
	In-line	D-Y59A-900	●	—	●	○	—	—	—	—	●	●	—	—	—					
		D-Y7P-900	●	—	●	○	—	—	—	—	●	●	—	—	—					
		D-Y59B-900	●	—	●	○	—	—	—	—	●	●	—	—	—					
		Perpendicular	D-Y69A-900	●	—	●	○	—	—	—	—	●	●	—	—	—				
			D-Y7PV-900	●	—	●	○	—	—	—	—	●	●	—	—	—				
			D-Y69B-900	●	—	●	○	—	—	—	—	●	●	—	—	—				
	Diagnostic indication (2-color indicator)	In-line	D-Y7NW-900	●	—	●	○	—	—	—	—	●	●	—	—	—				
			D-Y7PW-900	●	—	●	○	—	—	—	—	●	●	—	—	—				
			D-Y7BW-900	●	—	●	○	—	—	—	—	●	●	—	—	—				
			Perpendicular	D-Y7NWV-900	●	—	●	○	—	—	—	—	●	●	—	—	—			
				D-Y7PwV-900	●	—	●	○	—	—	—	—	●	●	—	—	—			
				D-Y7BwV-900	●	—	●	○	—	—	—	—	●	●	—	—	—			
		In-line	D-S991-901*1	●	—	●	○	—	—	—	—	—	—	—	—	—				
			D-S992-901*1	●	—	●	○	—	—	—	—	—	—	—	—	—				
			D-S9P1-901*1	●	—	●	○	—	—	—	—	—	—	—	—	—				
			D-S9P2-901*1	●	—	●	○	—	—	—	—	—	—	—	—	—				
			D-T991-901*1	●	—	●	○	—	—	—	—	—	—	—	—	—				
			D-T992-901*1	●	—	●	○	—	—	—	—	—	—	—	—	—				
	Perpendicular	D-S99V1-901*1	●	—	●	○	—	—	—	—	—	—	—	—	—					
		D-999V2-901*1	●	—	●	○	—	—	—	—	—	—	—	—	—					
		D-S9PV1-901*1	●	—	●	○	—	—	—	—	—	—	—	—	—					
		D-S9PV2-901*1	●	—	●	○	—	—	—	—	—	—	—	—	—					
		D-T99V1-901*1	●	—	●	○	—	—	—	—	—	—	—	—	—					
		D-T99V2-901*1	●	—	●	○	—	—	—	—	—	—	—	—	—					
In-line	D-S791-901*1	●	—	●	○	—	—	—	—	—	—	—	—	—						
	D-S792-901*1	●	—	●	○	—	—	—	—	—	—	—	—	—						
	D-S7P1-901*1	●	—	●	○	—	—	—	—	—	—	—	—	—						
	D-S7P2-901*1	●	—	●	○	—	—	—	—	—	—	—	—	—						
	D-T791-901*1	●	—	●	○	—	—	—	—	—	—	—	—	—						
	D-T792-901*1	●	—	●	○	—	—	—	—	—	—	—	—	—						
Reed auto switch	—	Grommet	Yes No	2-wire	In-line	D-A93L-900	—	—	●	—	—	—	—	—	—	—	—			
						D-A90L-900	—	—	●	—	—	—	—	—	—	—	—	—		

- * Solid state auto switches marked with a "○" are produced upon receipt of order.
- * Note that the individual auto switch with part number of "S□□" and "T□□" have the right-hand-type (□□□1) and the left-hand-type (□□□2).
When you order the actuator with two auto switches at the part number of the actuator, one each of the right-hand-type and the left-hand-type are shipped together with the actuator.
- * When the MHZ2-10, MHZL2-10, MHL2-10 to 40, or MHS3-32 air gripper is ordered with auto switch, mounting brackets are supplied with the air gripper.
When the auto switch is used at the square groove on the side with other cylinder bore sizes, or ordering only auto switches separately, mounting brackets (90-BMG2-012) are required. Order them separately. For details, refer to page 325.

Ordering the Auto Switches

Please be aware that the order part numbers for the air gripper mounted and individual auto switches are different.
 (Example) Part number for ordering D-M9BWL-900:
 • Air gripper mounted type: 25A-MHZ2-16D-M9BWL * Lead wire length symbols: 0.5 m..... Nil (Example) M9NW
 (Omit the first "D-" and the last "-900" or "-901".) 1 m..... M (Example) M9NWM
 • Individual auto switch: D-M9BWL-900 3 m..... L (Example) M9NWL
 (Place the order with the part number for auto switch shown in the table above.) 5 m..... Z (Example) M9NWZ

*1 Lead wire for a solid state auto switch with "-901" at the end of part number has been changed to a cable for a robot use.

25A- Series

Applicable Air Gripper Series

Type	Special function	Electrical entry	Indicator light	Auto switches					Air grippers									
				Wiring (Output)	Electrical entry direction	Auto switch model	Lead wire length [m]				Pre-wired connector	MHL2-Z	MHL2	MHF2	MHS3 MHS4	MHSJ3	MHY2	MHW2
							0.5 Nil	1 M	3 L	5 Z								
Solid state auto switch	—	Grommet	Yes	3-wire (NPN)	In-line	D-M9N-900	●	●	●	○	—	●	●	●	●	●	●	
						D-M9P-900	●	●	●	○	—	●	●	●	●	●	●	
				2-wire	In-line	D-M9B-900	●	●	●	○	—	●	●	●	●	●	●	●
						D-M9NV-900	●	●	●	○	—	●	●	●	●	●	●	●
				3-wire (NPN)	Perpendicular	D-M9PV-900	●	●	●	○	—	●	●	●	●	●	●	●
						D-M9BV-900	●	●	●	○	—	●	●	●	●	●	●	●
				3-wire (PNP)	Perpendicular	D-M9NW-900	●	●	●	○	—	●	●	●	●	●	●	●
						D-M9PW-900	●	●	●	○	—	●	●	●	●	●	●	●
				2-wire	In-line	D-M9BW-900	●	●	●	○	○	●	●	●	●	●	●	●
						D-M9NWV-900	●	●	●	○	—	●	●	●	●	●	●	●
				3-wire (NPN)	Perpendicular	D-M9PWV-900	●	●	●	○	—	●	●	●	●	●	●	●
						D-M9BWB-900	●	●	●	○	○	●	●	●	●	●	●	●
				3-wire (NPN)	In-line	D-Y59A-900	●	—	●	○	—	●	●	—	—	—	—	●
						D-Y7P-900	●	—	●	○	—	●	●	—	—	—	—	●
	2-wire	In-line	D-Y59B-900	●	—	●	○	—	●	●	—	—	—	—	●			
			D-Y69A-900	●	—	●	○	—	●	●	—	—	—	—	●			
	3-wire (NPN)	Perpendicular	D-Y7PV-900	●	—	●	○	—	●	●	—	—	—	—	●			
			D-Y69B-900	●	—	●	○	—	●	●	—	—	—	—	●			
	3-wire (NPN)	In-line	D-Y7NW-900	●	—	●	○	—	●	●	—	—	—	—	●			
			D-Y7PW-900	●	—	●	○	—	●	●	—	—	—	—	●			
	2-wire	In-line	D-Y7BW-900	●	—	●	○	—	●	●	—	—	—	—	●			
			D-Y7NWV-900	●	—	●	○	—	●	●	—	—	—	—	●			
	3-wire (NPN)	Perpendicular	D-Y7PWV-900	●	—	●	○	—	●	●	—	—	—	—	●			
			D-Y7BWB-900	●	—	●	○	—	●	●	—	—	—	—	●			
	3-wire (NPN)	In-line	D-S991-901*1	●	—	●	○	—	—	—	—	—	—	—	—			
			D-S992-901*1	●	—	●	○	—	—	—	—	—	—	—	—			
	3-wire (PNP)	In-line	D-S9P1-901*1	●	—	●	○	—	—	—	—	—	—	—	—			
			D-S9P2-901*1	●	—	●	○	—	—	—	—	—	—	—	—			
	2-wire	In-line	D-T991-901*1	●	—	●	○	—	—	—	—	—	—	—	—			
			D-T992-901*1	●	—	●	○	—	—	—	—	—	—	—	—			
	3-wire (NPN)	Perpendicular	D-S99V1-901*1	●	—	●	○	—	—	—	—	—	—	—	—			
			D-999V2-901*1	●	—	●	○	—	—	—	—	—	—	—	—			
	3-wire (PNP)	Perpendicular	D-S9PV1-901*1	●	—	●	○	—	—	—	—	—	—	—	—			
			D-S9PV2-901*1	●	—	●	○	—	—	—	—	—	—	—	—			
	2-wire	Perpendicular	D-T99V1-901*1	●	—	●	○	—	—	—	—	—	—	—	—			
			D-T99V2-901*1	●	—	●	○	—	—	—	—	—	—	—	—			
	3-wire (NPN)	In-line	D-S791-901*1	●	—	●	○	—	—	—	—	—	—	—	—			
			D-S792-901*1	●	—	●	○	—	—	—	—	—	—	—	—			
	3-wire (PNP)	In-line	D-S7P1-901*1	●	—	●	○	—	—	—	—	—	—	—	—			
			D-S7P2-901*1	●	—	●	○	—	—	—	—	—	—	—	—			
	2-wire	In-line	D-T791-901*1	●	—	●	○	—	—	—	—	—	—	—	—			
			D-T792-901*1	●	—	●	○	—	—	—	—	—	—	—	—			
Reed auto switch	—	Grommet	Yes No	2-wire	In-line	D-A93L-900	—	—	●	—	—	—	—	—	—	—		
						D-A90L-900	—	—	●	—	—	—	—	—	—	—	—	

- * Solid state auto switches marked with a "○" are produced upon receipt of order.
- * Note that the individual auto switch with part number of "S□□" and "T□□" have the right-hand-type (□□□1) and the left-hand-type (□□□2).
When you order the actuator with two auto switches at the part number of the actuator, one each of the right-hand-type and the left-hand-type are shipped together with the actuator.
- * When the MHZ2-10, MHZL2-10, MHL2-10 to 40, or MHS3-32 air gripper is ordered with auto switch, mounting brackets are supplied with the air gripper. When the auto switch is used at the square groove on the side with other cylinder bore sizes, or ordering only auto switches separately, mounting brackets (90-BMG2-012) are required. Order them separately. For details, refer to page 325.

Ordering the Auto Switches

Please be aware that the order part numbers for the air gripper mounted and individual auto switches are different.
 (Example) Part number for ordering D-M9BWL-900:

• Air gripper mounted type: 25A-MHZ2-16D-M9BWL	* Lead wire length symbols: 0.5 m..... Nil	(Example) M9NW
(Omit the first "D-" and the last "-900" or "-901".)	1 m..... M	(Example) M9NWM
• Individual auto switch: D-M9BWL-900	3 m..... L	(Example) M9NWL
(Place the order with the part number for auto switch shown in the table above.)	5 m..... Z	(Example) M9NWZ

*1 Lead wire for a solid state auto switch with "-901" at the end of part number has been changed to a cable for a robot use.

Applicable Electric Actuator Series

Auto switches										Electric actuators					
Type	Special function	Electrical entry	Indicator light	Wiring (Output)	Electrical entry direction	Auto switch model	Lead wire length [m]				Pre-wired connector	LEJS 40 to 63	LEKFS 16 to 40	LEY 16 to 40	LEYG 16 to 40
							0.5	1	3	5					
							Nil	M	L	Z	SDPC				
Solid state auto switch	—	Grommet	Yes	3-wire (NPN)	In-line	D-M9N-900	●	●	●	○	—	●	●	●	●
				3-wire (PNP)		D-M9P-900	●	●	●	○	—	●	●	●	●
				2-wire		D-M9B-900	●	●	●	○	—	●	●	●	●
				3-wire (NPN)	Perpendicular	D-M9NV-900	●	●	●	○	—	●	●	●	●
				3-wire (PNP)		D-M9PV-900	●	●	●	○	—	●	●	●	●
				2-wire		D-M9BV-900	●	●	●	○	—	●	●	●	●
	Diagnostic indication (2-color indicator)	Grommet	Yes	3-wire (NPN)	In-line	D-M9NW-900	●	●	●	○	—	●	●	●	●
				3-wire (PNP)		D-M9PW-900	●	●	●	○	—	●	●	●	●
				2-wire		D-M9BW-900	●	●	●	○	○	●	●	●	●
				3-wire (NPN)	Perpendicular	D-M9NWV-900	●	●	●	○	—	●	●	●	●
				3-wire (PNP)		D-M9P WV-900	●	●	●	○	—	●	●	●	●
				2-wire		D-M9B WV-900	●	●	●	○	○	●	●	●	●

- * Solid state auto switches marked with a “○” are produced upon receipt of order.
- * Auto switches cannot be ordered with the actuator part number. They should be ordered separately. Please refer below for ordering.

Ordering the Auto Switches

- Individual auto switch: D-M9BWL-900
(Place the order with the part number for auto switch shown in the table above.)
- * Lead wire length symbols: 0.5 m..... Nil (Example) M9NW
1 m..... M (Example) M9NWM
3 m..... L (Example) M9NWL
5 m..... Z (Example) M9NWZ

25A- Series Auto Switch Mounting

Refer to pages 315 to 322 for the cylinder series and auto switch combinations that are actually possible.

Band Mounting Type

Target auto switches: D-M9□-900, D-M9□W-900, D-M9BWSVDP-900, D-M9BWSVDP-900, D-A90L-900, D-A93L-900

Auto Switch Mounting Bracket Part Nos.

Cylinder series	Applicable bore size [mm]											
	8	10	12	16	20	25	32	40	50	63	80	100
25A-CDJ2 25A-CDJ2K 25A-CDBJ2	—	*1 25A-BJ7-010S	—	*1 25A-BJ7-016S	—	—	—	—	—	—	—	—
25A-CD85*4	25A-BJ7-008S	25A-BJ7-010S	25A-BJ7-012S	25A-BJ7-016S	25A-BM6-020S	25A-BM6-025S	—	—	—	—	—	—
25A-CDM2	—	—	—	—	*2 25A-BM6-020S	*2 25A-BM6-025S	*2 25A-BM6-032S	*2 25A-BM6-040S	—	—	—	—
25A-CDG1 25A-CDBG1	—	—	—	—	*3 25A-BMA4-020S	*3 25A-BMA4-025S	*3 25A-BMA4-032S	*3 25A-BMA4-040S	*3 25A-BMA4-050S	*3 25A-BMA4-063S	—	—
25A-MGG	—	—	—	—	*3 25A-BMA4-020S	*3 25A-BMA4-025S	*3 25A-BMA4-032S	*3 25A-BMA4-040S	*3 25A-BMA4-050S	—	—	—

- *1 The combination of the auto switch mounting band (BJ2-□□□S) with a stainless steel screw and the holder set (BJ3-1).
- *2 The combination of the auto switch mounting band (for BM2-□□□) and stainless steel screw (BBA4), and the holder set (BJ3-1).
- *3 The combination of the auto switch mounting band (for BMA2-□□□) and stainless steel screw (BBA4), and the holder set (BJ3-1).
- *4 D-A90L-900 and D-A93L-900 auto switches cannot be mounted on bore size ø8, ø10, or ø12 cylinders.

When the bore size is 16 mm or less

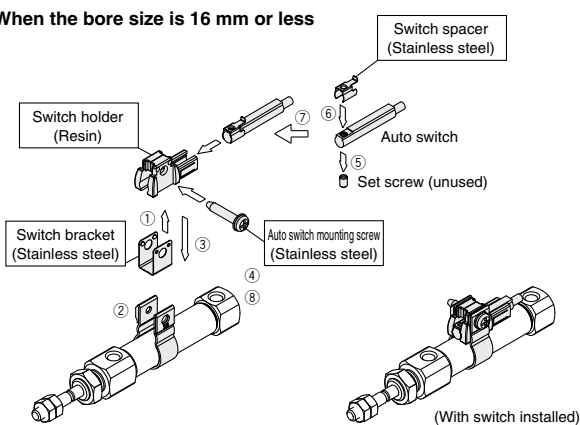

When the bore size is 20 mm or more

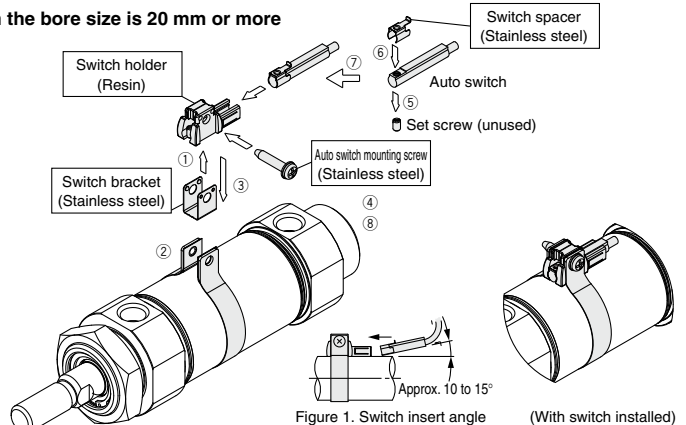

Applicable cylinder series: 25A-CDG1, 25A-CDBG1
Applicable auto switches : D-G5□-900, D-K59-900, D-G5□W-900, D-K59W-900, D-K59WSVDP-900

Auto Switch Mounting Bracket Part Nos.

Cylinder series	Applicable bore size [mm]	
	80	100
25A-CDG1 25A-CDBG1	BA-08S	BA-10S

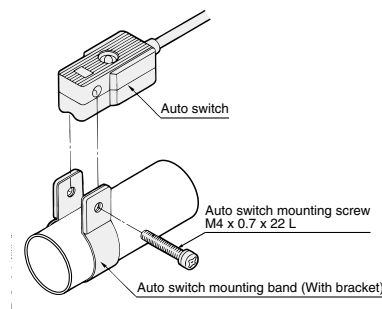

Tie-rod Mounting Type

Target auto switches: D-M9□-900, D-M9□V-900, D-M9□W-900, D-M9□WV-900, D-M9BWSVDP-900, D-M9BWSVDP-900
: D-A90L-900, D-A93L-900

Auto Switch Mounting Bracket Part Nos.

Cylinder series	Applicable bore size [mm]										
	32	40	50	63	80	100	125	140	160	200	
25A-MDB	90-BMB5-032	90-BMB5-032	90-BA7-040	90-BA7-040	90-BA7-063	90-BA7-063	—	—	—	—	
25A-C96SD 25A-C96ND	90-BMB5-032	90-BMB5-032	90-BA7-040	90-BA7-040	90-BA7-063	90-BA7-063	*1 90-BA7-080	—	—	—	
25A-CDA2	—	90-BA7-040	90-BA7-040	90-BA7-063	90-BA7-080	90-BA7-080	—	—	—	—	
25A-CDS2 25A-CDNS	—	—	—	—	—	—	25A-BS6-125	25A-BS6-125	25A-BS6-160	—	
25A-MDWB	90-BMB5-032	90-BMB5-032	90-BA7-040	90-BA7-040	90-BA7-063	90-BA7-063	—	—	—	—	
25A-C95SD	—	—	—	—	—	—	—	—	25A-BS6-160	25A-BS6-160	

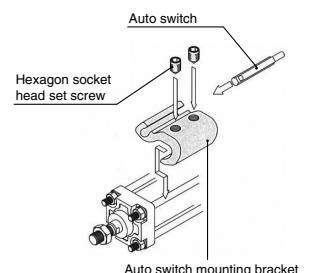

*1 Only applicable to the 25A-C96SD

Refer to pages 315 to 322 for the cylinder series and auto switch combinations that are actually possible.

Rail Mounting Type

Target auto switches: D-M9N(V)-900, D-M9P(V)-900, D-M9B(V)-900, D-M9NW(V)-900, D-M9PW(V)-900, D-M9BW(V)-900, D-A90L-900, D-A93L-900

Auto Switch Mounting Bracket Part No.

Cylinder series	Applicable bore size [mm]							
	20	25	32	40	50	63	80	100
25A-CDBQ2 25A-CDLQ	—	—	25A-BQ2-032			—	—	—

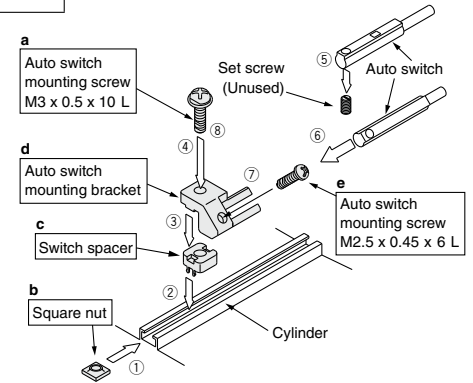

Target auto switches: D-F79-900, D-F7P-900, D-J79-900, D-F7NV-900, D-F7PV-900, D-F7BV-900, D-F79W-900, D-F7PW-900, D-J79W-900, D-F7NWV-900, D-F7BWV-900

Auto Switch Mounting Bracket Part No.

Cylinder series	Applicable bore size [mm]								
	20	25	32	40	50	63	80	100	
25A-CDBQ2 25A-CDLQ	—	—	25A-BQ-2						—

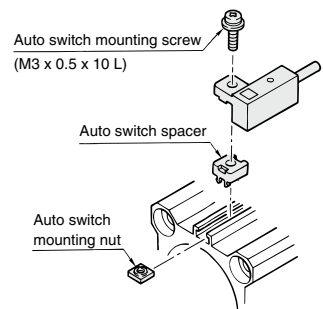

25A- Series

Refer to pages 315 to 322 for the cylinder/air gripper series and auto switch combinations that are actually possible.
For combinations other than those shown in the table below, direct mounting without the use of auto switch mounting brackets is possible.

Direct Mounting Type

Target auto switches: D-M9□-900, D-M9□V-900, D-M9□W-900,
D-M9□WV-900, D-M9BWSDPC-900,
D-M9BWVSDPC-900
D-F8□-900
: D-A90L-900, D-A93L-900

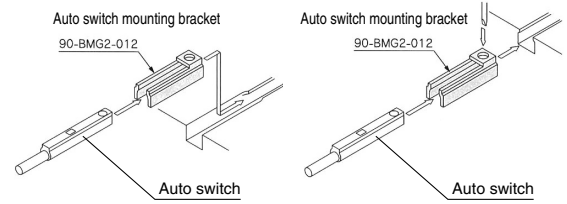

Auto Switch Mounting Bracket Part Nos.

Cylinder series Air gripper series	Applicable bore size [mm]													
	4	6	10	12	15	16	20	25	32	40	50	63	80	100
25A-MDU	—	—	—	—	—	—	—	MUZ-025	MUZ-025	MUZ-025	MUZ-025	MUZ-025	—	—
25A-MY1B	—	—	—	—	—	Not required	Not required	BYM3-016	BYM3-016	BYM3-016	—	90-BMG2-012	—	—
25A-MY1M	—	—	—	—	—	Not required	Not required	90-BMG2-012	90-BMG2-012	90-BMG2-012	90-BMG2-012	90-BMG2-012	—	—
25A-MY1C	—	—	—	—	—	Not required	Not required	90-BMG2-012	90-BMG2-012	90-BMG2-012	90-BMG2-012	90-BMG2-012	—	—
25A-MY1H	—	—	—	—	—	Not required	Not required	BYM3-016	BYM3-016	BYM3-016	—	—	—	—
25A-MY3□	—	—	—	—	—	BYM3-016	BYM3-016	BYM3-016	BYM3-016	BYM3-016	BYM3-016	BYM3-016	—	—
25A-CY3R	—	—	—	—	Not required	—	Not required	90-BMG2-012	90-BMG2-012	90-BMG2-012	90-BMG2-012	90-BMG2-012	—	—
25A-RSH	—	—	—	—	—	—	90-BMG2-012	—	90-BMG2-012	—	—	—	—	—
25A-MHZ2	—	—	90-BMG2-012	—	—	*1	*1	*1	*1	*1	—	—	—	—
25A-MHZL2	—	—	90-BMG2-012	—	—	*1	*1	*1	—	—	—	—	—	—
25A-MHL2	—	—	90-BMG2-012	—	—	90-BMG2-012	90-BMG2-012	90-BMG2-012	90-BMG2-012	90-BMG2-012	—	—	—	—
25A-MHS3 25A-MHS4	—	—	—	—	—	Not required	Not required	Not required	90-BMG2-012	—	—	—	—	—

*1 When mounting D-M9 type of auto switch onto the square groove of the side of the air gripper, the auto switch mounting bracket (90-BMG2-012) is required.